

**RICOH**



# Aficio<sup>TM</sup>

## CL800

### Setup Guide

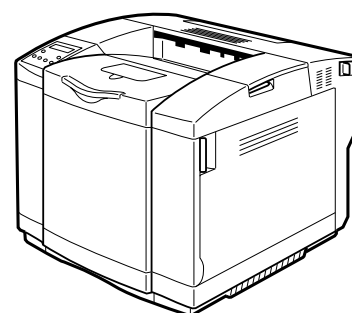

Read this manual carefully before you use this product and keep it handy for future reference. For safe and correct use, please be sure to read the Safety Information in this manual before using the machine.

## Introduction

This manual describes detailed instructions on the operation and notes about the use of this machine. To get maximum versatility from this machine all operators are requested to read this manual carefully and follow the instructions. Please keep this manual in a handy place near the machine.

## Power Source

220-240 V, 50/60 Hz, 6 A or more

Please be sure to connect the power cable to a power source as above.

## Operator Safety:

This printer is considered a class 1 (3B) laser device, safe for office/ EDP use. The printer contains 5 milliwat, 770 - 795 nanometer wavelength, AlGaAs Laser Diode. Direct (or indirect reflected) eye contact with the laser beam might cause serious eye damage. Safety precautions and interlock mechanisms have been designed to prevent any possible laser beam exposure to the operator.

The following label is attached on right side of the printer.



## Laser Safety:

The optical housing unit can only be repaired in a factory or at a location with the requisite equipment. The laser subsystem is replaceable in the field by a qualified customer engineer. The laser chassis is not repairable in the field. Customer engineers are therefore directed to return all chassis and laser sub-systems to the factory or service depot when replacement of the optical subsystem is required.

## Important

Contents of this manual are subject to change without prior notice. In no event will the company be liable for direct, indirect, special, incidental, or consequential damages as a result of handling or operating the machine.

## Caution:

Use of controls or adjustment or performance of procedures other than those specified in this manual might result in hazardous radiation exposure.

Do not make copies of any item for which copying is prohibited by law.

Copying the following items is normally prohibited by local law:

Bank bills, revenue stamps, bonds, stock certificates, bank drafts, checks, passports, driver's licenses.

Do not attempt any maintenance or troubleshooting other than that mentioned in this manual. This printer contains a laser beam generator and direct exposure to laser beams can cause permanent eye damage.

For good print quality, the supplier recommends that you use genuine toner, maintenance kits and parts from the supplier.

The supplier shall not be responsible for any damage or expense that might result from the use of consumables (toner, maintenance kits and parts) other than genuine consumables from the supplier with your office products.

# Table of Contents

---



<b>Safety Information</b> .....	<b>Safety-1</b>
<b>Chapter 1 Before Using the Printer</b> .....	<b>1-1</b>
1. PC Connection .....	1-2
2. Names of Printer Components .....	1-3
<b>Chapter 2 Installation</b> .....	<b>2-1</b>
1. Checking Your Package .....	2-2
2. Procedure for Installation.....	2-4
3. Checking Where to Install the Printer .....	2-5
4. Checking the Power Source .....	2-7
5. Installing the Printer .....	2-8
6. Preparing the printer .....	2-9
7. Connecting the Power Cord .....	2-14
8. Ensuring the Printer Operation .....	2-15
9. Connecting the Printer to a PC.....	2-21
10. Installing the Printer Driver .....	2-22

# Safety Information

When using your printer, the following safety precautions should always be followed.

## Safety During Operation

In this manual, the following important symbols are used:



### **WARNING:**

*Indicates a potentially hazardous situation which, if instructions are not followed, could result in death or serious injury.*



### **CAUTION:**

*Indicates a potentially hazardous situation which, if instructions are not followed, may result in minor or moderate injury or damage to property.*

## **WARNING**

- It is dangerous to handle the plug with wet hands. Doing this may result in receiving an electric shock.
- Connect the power cord directly into a wall outlet and never use an extension cord.
- Disconnect the power plug (by pulling the plug, not the cable) if the power cable or plug becomes frayed or otherwise damaged.
- Confirm that the wall outlet is near the machine and freely accessible, so that in event of an emergency, it can be unplugged easily.
- Only connect the machine to the power source described in the manual.
- Avoid multi-wiring.
- Do not damage, break or make any modifications to the power cord.
- Do not place heavy objects on it, pull it hard or bend it more than necessary. These actions could cause an electric shock or fire.
- To avoid hazardous electric shock or laser radiation exposure, do not remove any covers or screws other than those specified in this manual.
- Turn off the power and disconnect the power plug (by pulling the plug, not the cable) if any of the following conditions exists:
  - You spill something into the equipment.
  - You suspect that your equipment needs service or repair.
  - Your equipment's cover has been damaged.
  - Do not incinerate spilled toner or used toner. Toner dust might ignite when exposed to an open flame.
  - Disposal should take place at an authorized dealer or an appropriate collection site. If you dispose of the used toner containers yourself, dispose of them according to local regulations.
  - Dispose of the used toner cartridge in accordance with the local regulation.
  - Do not take apart or attempt any modifications to this machine. There is a risk of fire, electric shock, explosion or loss of sight. If the machine has laser systems, there is a risk of serious eye damage.
  - Do not incinerate spilled toner or used toner. Toner dust is flammable and might ignite when exposed to an open flame.
  - Disposal should take place at an authorized dealer or an appropriate collection site.
  - If you dispose of the used toner cartridges yourself, dispose of them according to local regulations.
  - Do not remove any covers or screws other than those specified in this manual. Some parts of the machine are at a high voltage and could give you an electric shock. Also, if the machine has laser systems, direct (or indirect) reflected eye contact with the laser beam may cause serious eye damage. When the machine needs to be checked, adjusted, or repaired, contact your service representative.

## CAUTION

- Do not eat or swallow toner.
- Keep toner (used or unused) and toner cartridge out of reach of children.
- Do not put an object on the right cover when it is open.
- Protect the equipment from dampness or wet weather, such as rain, snow, and so on.
- Unplug the power cord from the wall outlet before you move the equipment. While moving the equipment, you should take care that the power cord will not be damaged under the equipment.
- When you disconnect the power plug from the wall outlet, always pull the plug (not the cable).
- Do not allow paper clips, staples, or other small metallic objects to fall inside the equipment.
- For environmental reasons, do not dispose of the equipment or expended supply waste at household waste collection points. Disposal can take place at an authorized dealer or at appropriate collection sites.
- The inside of the machine becomes very hot. Do not touch the parts with a “v” label (means hot surface). Touching a part with a “” label (means hot surface) could result in a burn.
- The fusing unit becomes very hot. When installing the new fusing unit, turn off the printer and wait about 30 minutes. After that, install the new fusing unit. Not waiting for the unit to cool down can result in a burn.
- Do not pull out the fusing unit forcefully. It may cause the unit to fall and result in an injury.
- When touching the fusing unit, do not touch any areas other than the handle as it may cause a burn.
- When removing misfed paper, do not touch the fusing unit because it could be very hot.
- To prevent an injury, this printer should be lifted by at least two people.
- The printer weights approximately 31.5 kg (69.4 lb). When moving the printer, use the inset grips on both sides, and lift slowly. The printer will break or cause injury if dropped.
- Before installing options, the machine should be turned off and unplugged for at least half an hour. Components inside the machine become very hot, and can cause a burn if touched.
- Lifting the paper feed unit carelessly or dropping it may cause an injury.
- Lifting the duplex unit carelessly or dropping it may cause an injury.
- Do not touch the inside of the controller board compartment. It may cause a machine malfunction or a burn.
- Keep the machine away from humidity and dust. A fire or an electric shock might occur.
- Place the machine on a strong and level surface. Otherwise, the machine might fall and result in an injury.

## CAUTION

- If you use the machine in a confined space, confirm that there is a continuous flow of air.
- When pulling the paper tray out, be careful not to pull it strongly. If you do, the tray might fall and cause an injury.
- This product uses low frequency electromagnetic fields and may cause harmful interference to sensitive medical implant devices. If you have a cardiac pacemaker or implantable defibrillator, please consult your doctor for additional suggestion or advice.
- When moving the machine, each person should hold the handles that are located on opposite sides, and then lift it slowly. Lifting it carelessly or dropping it may cause an injury.
- When you move the printer, remember to unplug the power cord from the wall outlet to avoid a fire or an electric shock.
- When you pull out the plug from the socket, grip the plug, not the cord, to avoid damaging the cord and causing a fire or an electric shock.
- When moving the printer after use, do not take out any of the Toners, Photo Conductor Units, nor the Waste Toner Bottle to prevent toner spill inside the machine.
- When lifting the machine, use the inset grips on both sides. Otherwise the printer could break or cause an injury if dropped.
- Before moving the machine, unplug the power cord from the wall outlet. If the cord is unplugged abruptly, it could become damaged. Damaged plugs or cords can cause an electrical or fire hazard.
- Our products are engineered to meet the highest standards of quality and functionality. When purchasing expendable supplies, we recommend using only those specified by an authorized dealer.

**This machine has labels for  WARNING and  CAUTION at the positions shown below. For safety, please follow the instructions and handle the machine as indicated.**

# ⚠ Warning Labels

The printer has warning labels on the following positions.

Should the warning label be damaged or peeled off, contact your dealer or service representative.

## ◆ Printer body



CAUTION  
VORSICHT  
注意

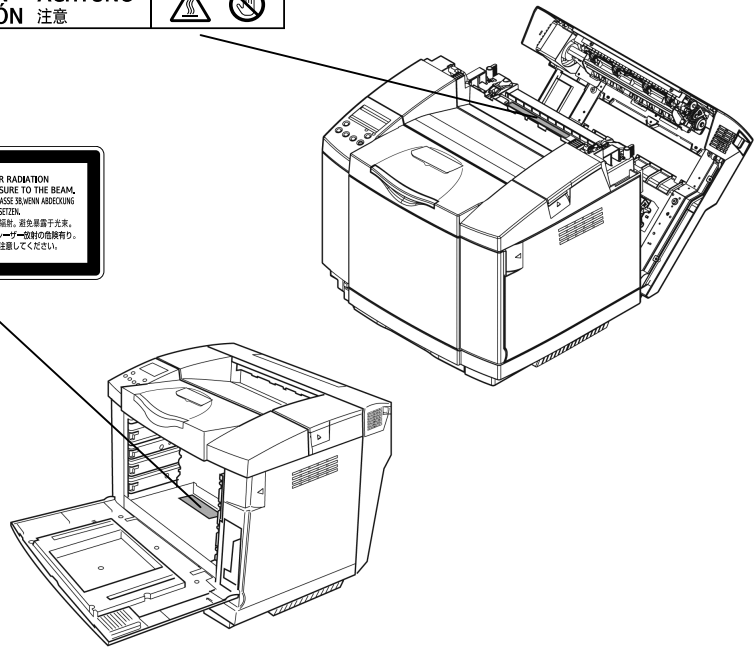

## ◆ Toner cartridge

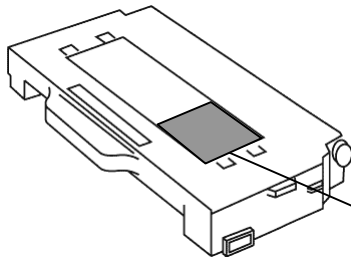

## ◆ Waste toner pack

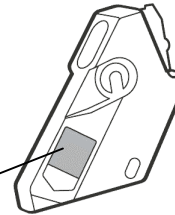



# ENERGY STAR Program

<p>ENERGY STAR®</p> 	<p>As an ENERGY STAR Partner, we have determined that this machine model meets the ENERGY STAR Guidelines for energy efficiency.</p>
---	--

The ENERGY STAR Guidelines intend to establish an international energy-saving system for developing and introducing energy-efficient office equipment to deal with environmental issues, such as global warming. When a product meets the ENERGY STAR Guidelines for energy efficiency, the Partner shall place the ENERGY STAR logo onto the machine model. This product was designed to reduce the environmental impact associated with office equipment by means of energy-saving features, such as Low-power mode.

- **Low-power Mode (Energy Saver mode)**

This printer automatically lowers its power consumption 30 minutes after the last operation has been completed. To exit Low-power (Energy Saver) mode, press any key on the control panel. For more information about how to configure Energy Saver mode, see Operating Instructions attached to the CD-ROM.

- **Specifications**

Energy Saver mode	Power Consumption	15 W or less
	Default Time	30 minutes
	Recovery Time	45 seconds or less

# German acoustic statement

The following measurements were made in accordance with ISO7779 and reported in conformance with ISO 9296.

- **Noise Emission:**

**Sound Power Level**

	<b>Mainframe only</b>
Stand-by	54 dB (A)
During Printing	66 dB (A)

**Sound Power Level**

	<b>Mainframe only</b>
Stand-by	46 dB (A)
During Printing	60 dB (A)

# Chapter 1 Before Using the Printer

- 1. PC Connection -----1-2
- 2. Names of Printer Components -----1-3

# 1. PC Connection

You can connect the printer directly to a Windows® PC using the USB interface supported in the standard configuration.

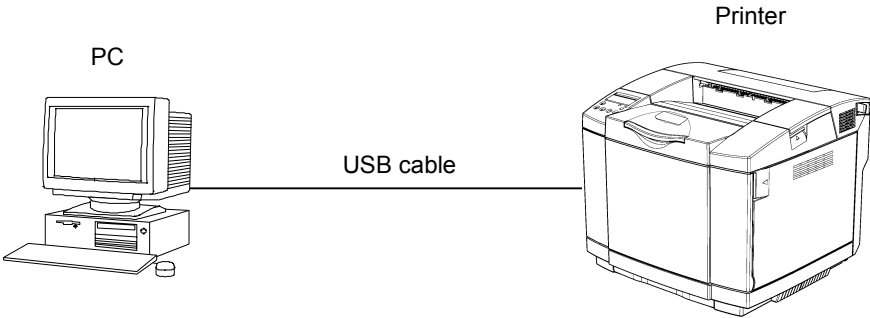

## 2. Names of Printer Components

### 2.1 Front View with Full Options

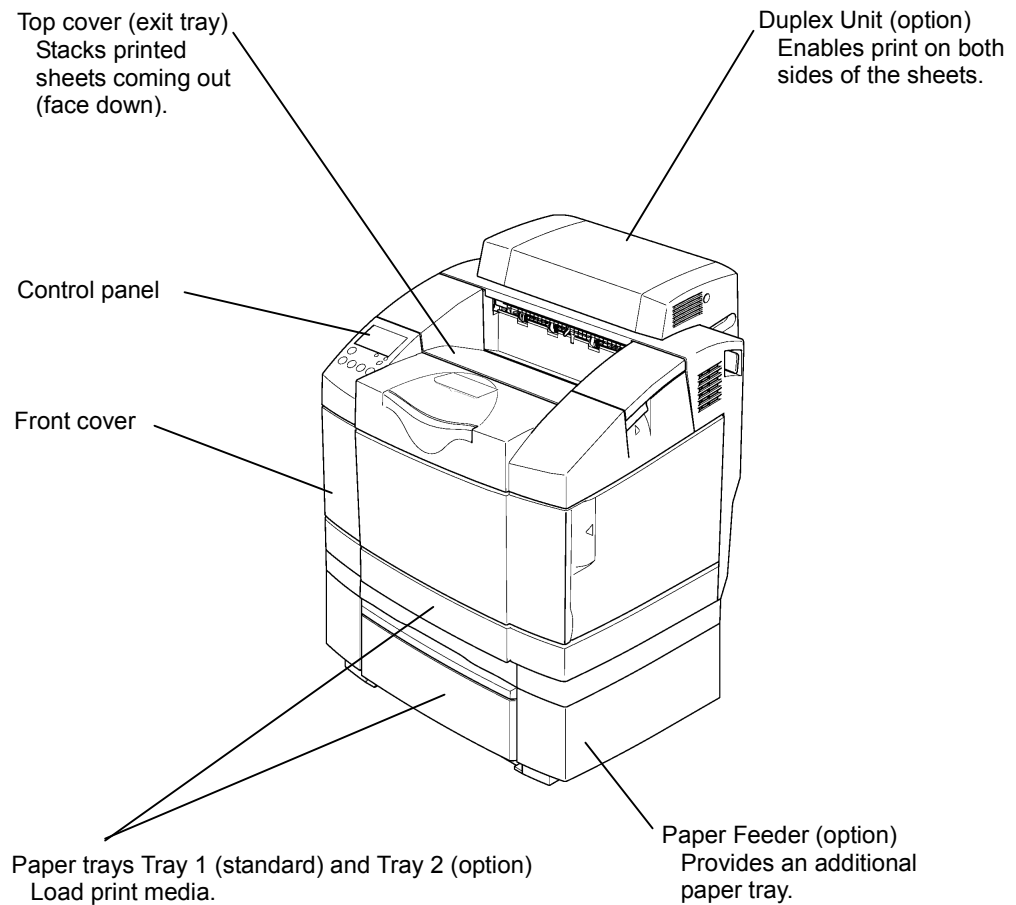

## 2.2 Rear View (without Duplex Unit)

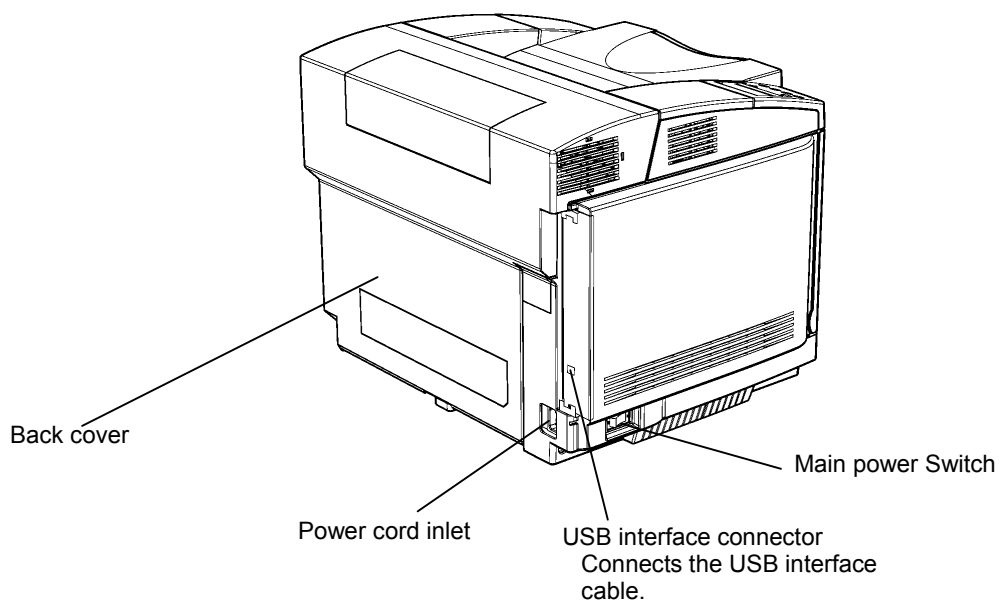

## 2.3 Rear View (with Duplex Unit)

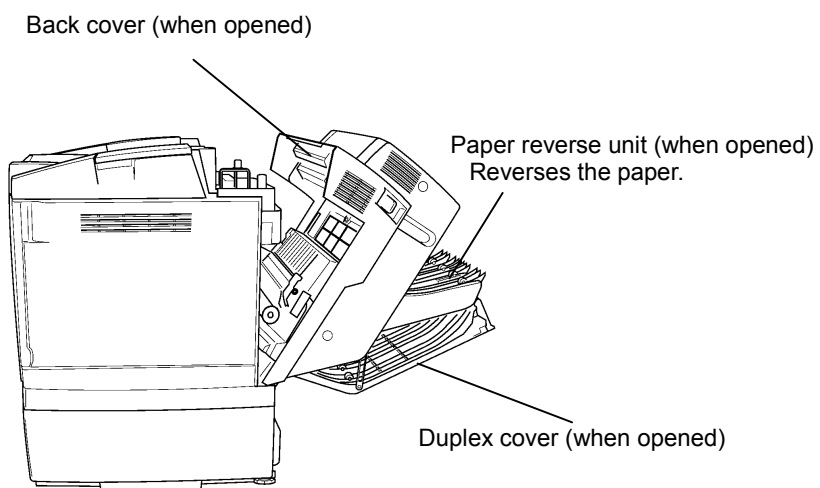

## 2.4 Internal View

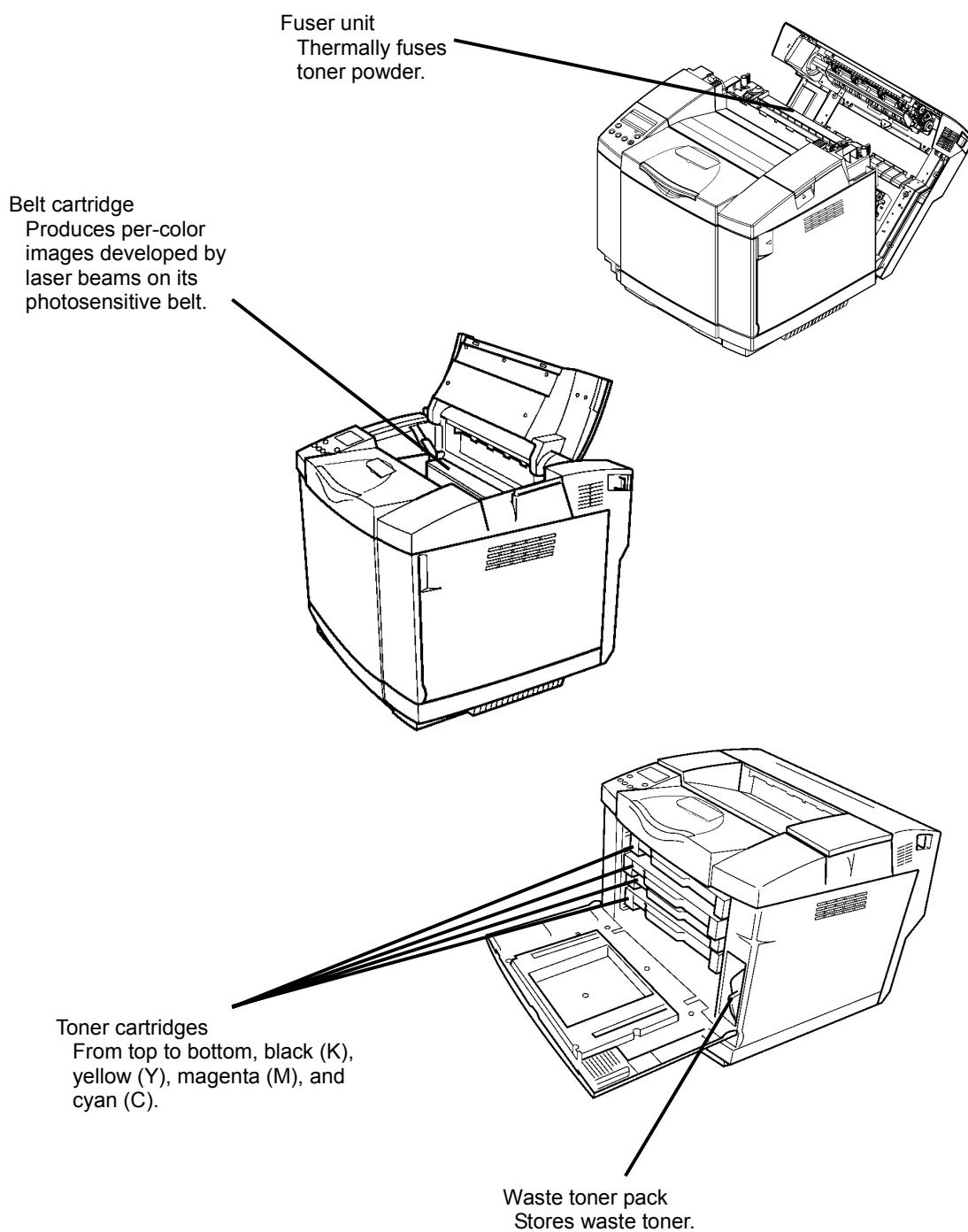





## Chapter 2 Installation

1. Checking Your Package -----	2-2
2. Procedure for Installation -----	2-4
3. Checking Where to Install the Printer -----	2-5
4. Checking the Power Source -----	2-7
5. Installing the Printer -----	2-8
6. Preparing the printer -----	2-9
7. Connecting the Power Cord -----	2-14
8. Ensuring the Printer Operation -----	2-15
9. Connecting the Printer to a PC -----	2-21
10. Installing the Printer Driver -----	2-22

# 1. Checking Your Package

Before installing the printer, check that all the items are contained in the package. Should any components be missing or damaged, contact your dealer.

- **Printer**

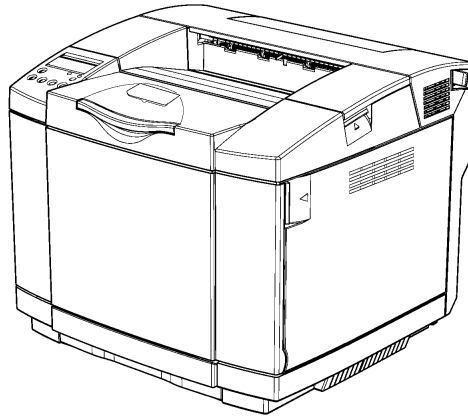

- **Power cord**

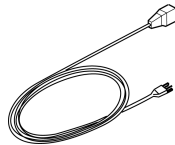

- **Accessory kit**

- Setup Guide (This manual)
- Option Setup Guide
- Two CD-ROMs (Printer driver, Manuals)

- **Starter kit**

- Belt cartridge

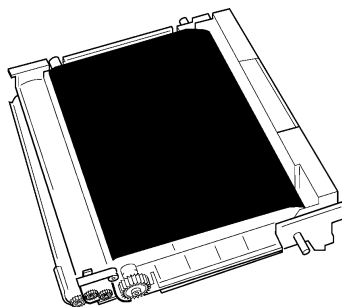

The printer includes toner cartridges K, Y, M and C (one each), a waste toner pack and a fuser unit as consumables.

In this manual, the "Photo Conductor Unit Type 140" is called the "Belt cartridge" and the "Waste Toner Bottle Type 140" is called the "Waste toner pack".

### **Accessories and Consumables**

- The printer driver CD-ROM contains the printer driver. The manual CD-ROM contains Operating Instructions, Acrobat Reader, and other items.
- The printer includes toner cartridges K, Y, M and C (one of each) and a waste toner pack as consumables.
- The toner cartridge included in the starter kit has the capacity to print no more than 1500 pages. For details on when to replace consumables, see Operating Instructions attached to the CD-ROM.

## 2. Procedure for Installation

Follow the procedure below when you install the printer.

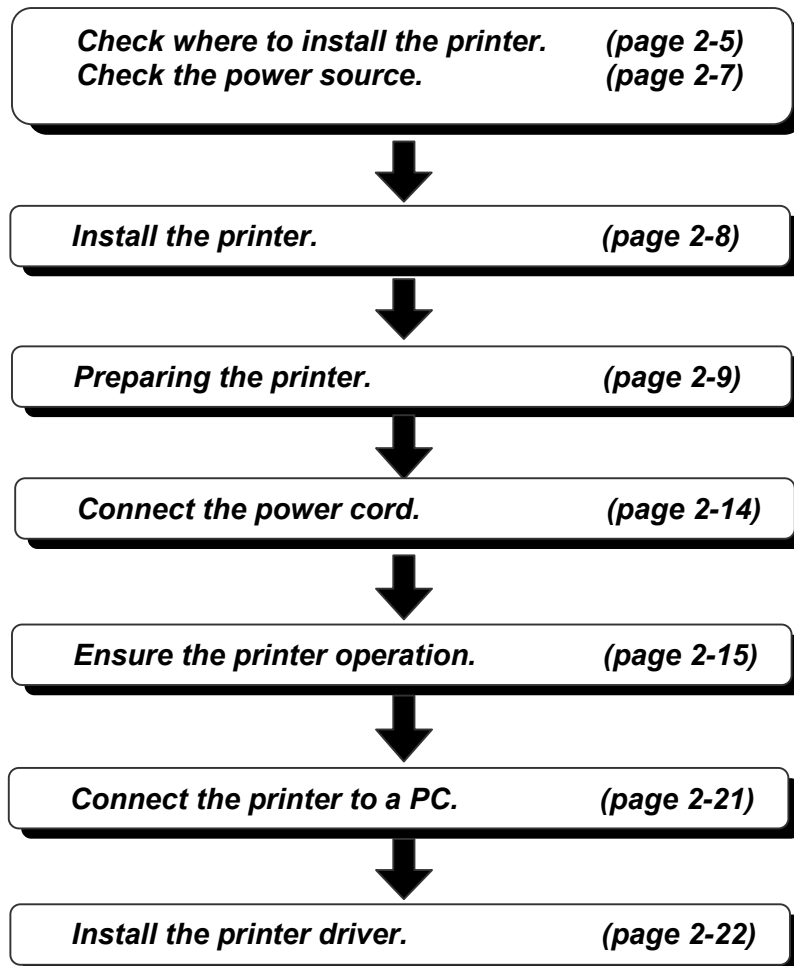

# 3. Checking Where to Install the Printer

Before installing the printer, check the environment and space for the installation.

## 3.1 For Proper Operation

- Supplies and parts, including toner, and photo conductor unit have been evaluated for quality based on a benchmark for recommended products. Use recommended supplies and parts to maintain this standard and achieve high quality results.
- Place this printer on a level, stable table that is not curved. Do not place across two tables. The machine must be level within 4.5 mm front to rear, and left to right.
- Recommended temperature and humidity.

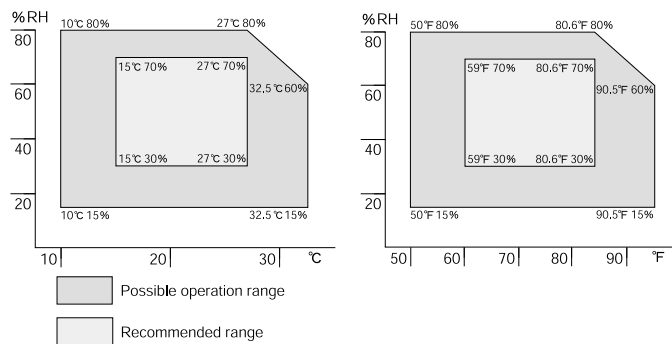

- To load paper, replace consumables, and resolve paper jams, etc., leave a clearance as shown below.

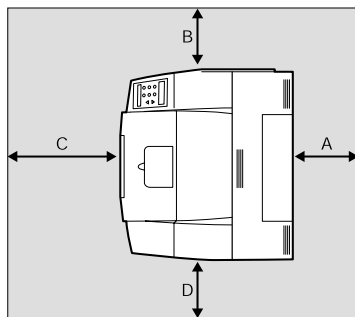

- A: more than 25 cm (More than 35 cm when the AD460 (duplex unit) is attached.)
- B: more than 20 cm
- C: more than 70 cm
- D: more than 50 cm

- When moving from a cold to warm location, or if the local temperature rises suddenly, condensation may occur inside. If this occurs, leave the machine unused for at least one hour to let it acclimatize.
- Extreme temperature rise inside the machine may cause malfunctions. Do not place anything in the immediate area of the exhaust and intake vents.
- Always keep all covers closed.
- During printing, do not open the cover of any parts, and do not move the printer.
- Do not pull out the paper tray during printing. Printing will stop and paper will jam.

- Prevent foreign objects, such as paper clips, etc., from falling inside the printer.
- During printing, do not switch the power off and do not unplug the power cable. Sudden power interruptions can cause malfunctions.
- While printing, protect the printer from external shocks, such as arranging papers on top of the printer.
- Depending on temperature and humidity, during printing a while steam may come from the printing paper when it leaves the printer.
- The paper exit and nearby parts may become hot during printing. This is normal and no reason for concern.
- This unit is designed and manufactured to have a life expectancy of 5 years based on a monthly printing volume of 2,000 sheets (A4 with a 1:1 ratio of color printing and monochrome printing) when the power is on for a total of 8 hours per day). If the monthly number of printed pages exceeds 10,000 sheets or if the time the power is on exceeds 8 hours a day, life expectancy shortens. The 5 years figure is also based on a ratio of 1:1 of color printing and monochrome printing. Should the number of sheets of color printing exceed this ratio, the total number decreases.

## 4. Checking the Power Source

Check the power source for the printer.

### Input Power Requirements

Supply voltage: 220 – 240 VAC

Frequency: 50 Hz  $\pm$ 2 Hz



### WARNING

- **Confirm that the wall outlet is near the printer and freely accessible, so that in event of an emergency, it can be unplugged easily.**
- **Only connect the printer to the power source described on this page.**
- **Avoid multi-wiring.**

### Power Consumption

The printer consumes power of up to 1,300 W.

When determining the power source for the printer, consider its electric power capacity as well. Should the rated power capacity be exceeded, the circuit breaker may be shut down, affecting equipment sharing the power source.

## 5. Installing the Printer



### CAUTION

- The printer weights approximately 31.5 kg (69.4 lb). When moving the printer, use the inset grips on both sides, and lift slowly. The printer will break or cause injury if dropped.
- To prevent an injury, this printer should be lifted by at least two people.

### Installation procedure

- (a) Take out the printer from its packing box. You will find four grips at the bottom of the printer. Have two or more persons grasp these grips firmly to carry the printer.

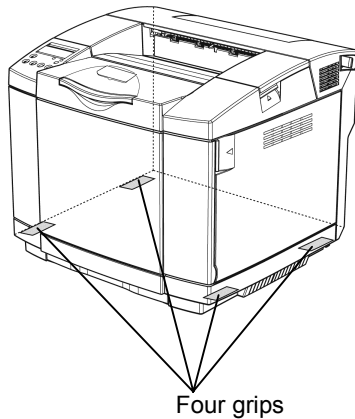

Four grips

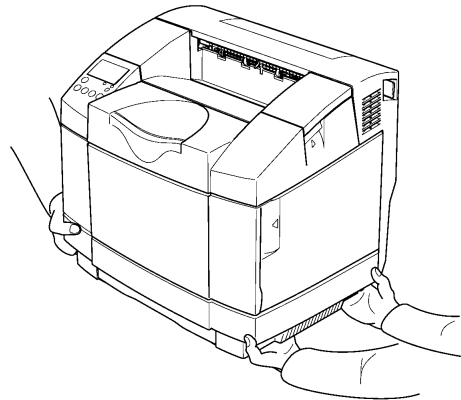

- (b) Install the printer in a suitable place.



## 6. Preparing the printer

Install the consumables into the printer.

### 6.1 Toner Cartridges

Install the toner cartridges for all four colors into the printer.

Note on handling the toner cartridge
Handle the toner cartridge with its label facing upward. Do not install the cartridge upside-down or reverse it.

Install the cyan (C), magenta (M), yellow (Y) and black (K) toner cartridges as shown below.

#### Installation procedure

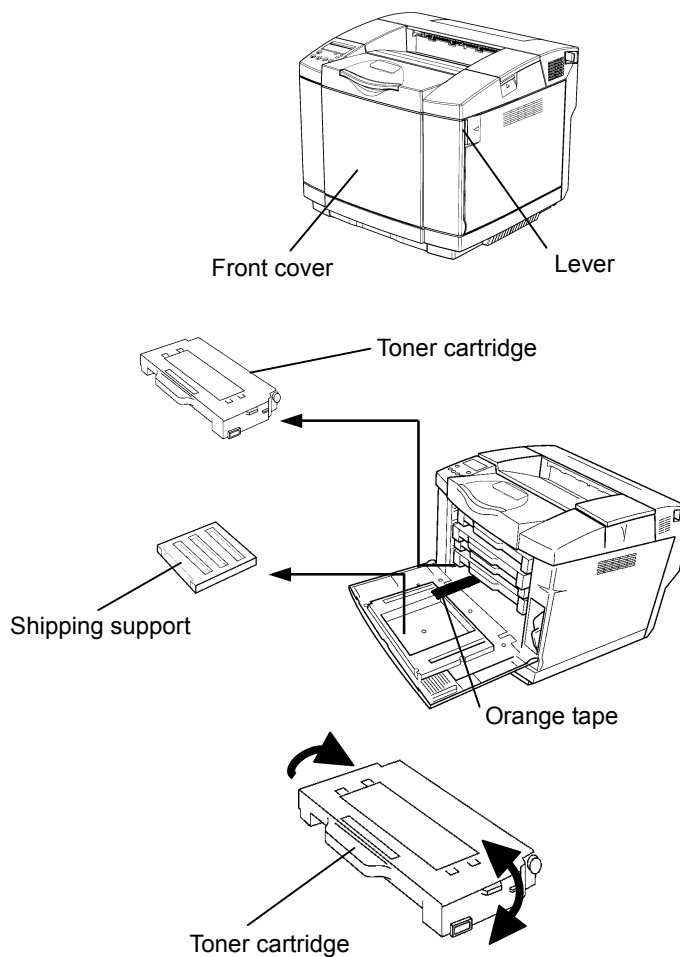
- 
- (a) Unlock the lever on the front cover and open the front cover.
- (b) Remove the shipping support and four toner cartridges.
- (c) Pull out the orange tape to remove the protective paper.
- (d) Rock the toner cartridge three or four times in the direction of arrows to level out the toner inside the cartridge.

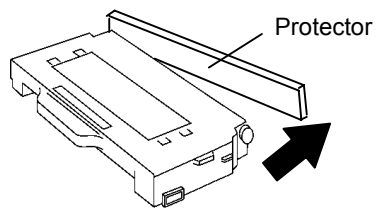

- (e) Peel off the tape, and remove the protector for the toner cartridge from the right. Do not lose the protector because it is necessary for transporting the printer.

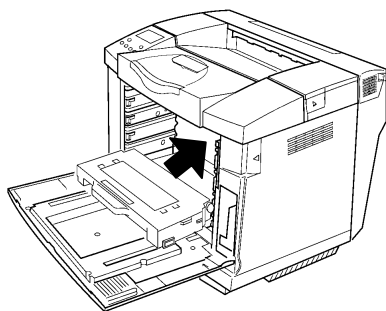

- (f) For each setting, softly force the toner cartridge along the guides in the printer.

Install the cyan (C), magenta (M), yellow (Y) and black (K) toner cartridges in that order.

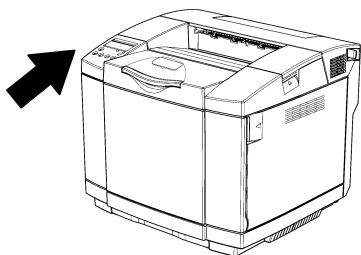

- (g) Close the front cover securely by pushing it until it locks.

## 6.2 Belt Cartridge

Install the belt cartridge in the printer as illustrated below. Pay attention to the following notes:

### Notes on handling the belt cartridge

- Do not touch the green surface of the belt cartridge with bare hands or gloves. This could damage the belt cartridge and reduce the print quality.
- A white powder has been intentionally adhered to the surface of the belt cartridge. Do not attempt to wipe it off. Removal will prevent normal printing.

### Installation procedure

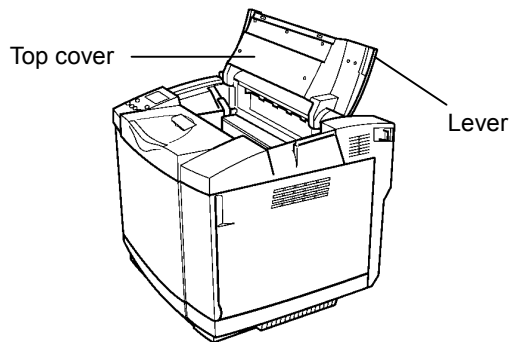

- (a) Pull up the lever on the top cover and open the top cover until it stops.
- **Keep the top cover fully open during the replacement work.**

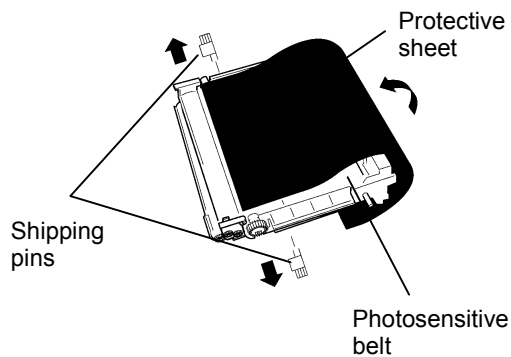

- (b) Remove the two shipping pins of a new belt cartridge.
- (c) Remove the protective sheet for the belt cartridge. Pay attention to the following:
- **Do not touch the photosensitive belt.**
  - **Do not wipe off any of the white powder adhering to the photosensitive belt.**

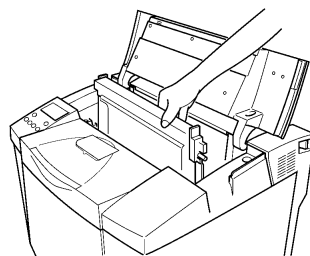

- (d) With the photosensitive belt facing front, slide the belt cartridge into the printer along the guide.

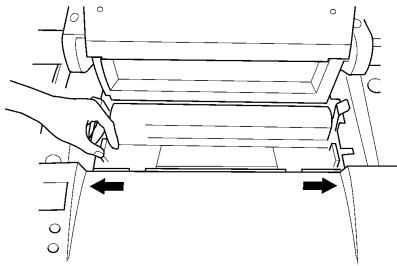

(e) Restore the lock levers .

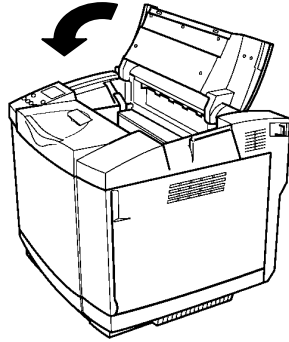

(f) Close the top cover by pushing it until it locks.

- **While closing, keep holding the top cover until you close it to the locked position.**

## 6.3 Tension release piece of the Fuser unit

Remove the tension release piece of the Fuser unit in the printer as illustrated below.

### Installation procedure

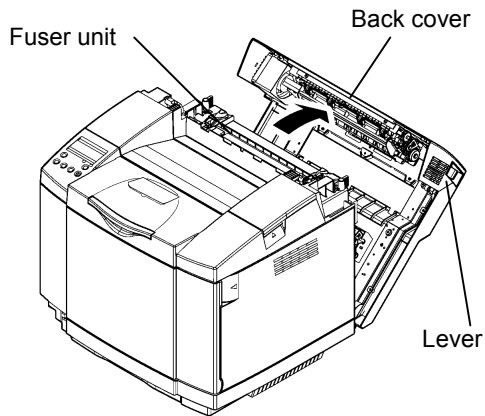

- (a) Pull the lever on the Back cover to unlock the back cover, and open the back cover until it stops.
  - **Keep the top cover fully open during the replacement work.**

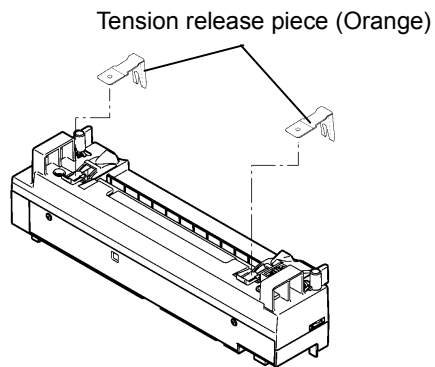

- (b) Pull out the tension release piece (orange colored) provided at the left and right side of fuser unit
- (c) Close the back cover and push it until it locks.
  - **While closing, keep holding the back cover until you close it to the locked position.**

## 7. Connecting the Power Cord

Connect the power cord to the printer as shown below.

 <b>WARNING</b>
<ul style="list-style-type: none"><li>• When you pull the plug out of the socket, grip the plug to avoid damaging the cord and causing a fire or an electric shock.</li><li>• It is dangerous to handle the plug with wet hands. Doing this may result in receiving an electric shock.</li></ul>

### Procedure for connecting the power cord

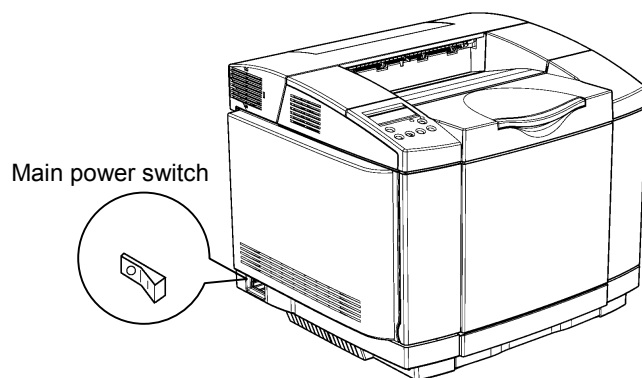

- (a) Before connecting the power cord, check that the main power switch for the printer is placed in the OFF position.

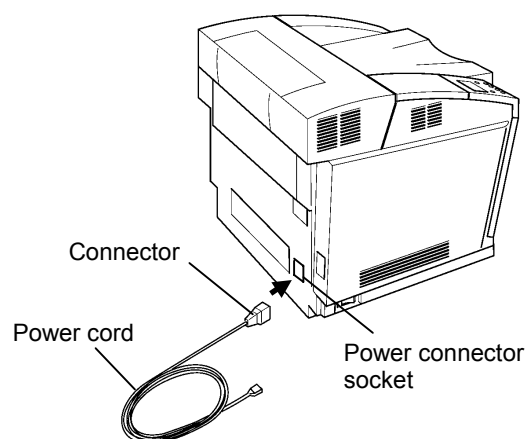

- (b) Insert the connector of the power cord into the printer socket.

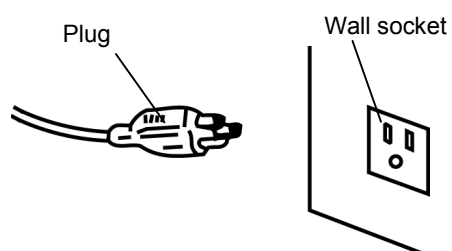

- (c) Insert the plug of the power cord into a grounded wall socket.

## 8. Ensuring the Printer Operation

Ensure the printer's operation according to the procedures shown below.

**Start ensuring the printer operation after the printer becomes accustomed to the room temperature, particularly in winter. Operating the printer not warm enough could cause a jam or trouble in printed images.**

Each procedure assumes the use of standard, A4-size paper for the test print after the printer installation.

### 8.1 Supplying Paper

**Before turning on the printer, supply paper in the paper tray as shown below.**

For details of the printer driver setting for the paper, see Operating Instructions attached to the CD-ROM.

#### Procedure for supplying paper

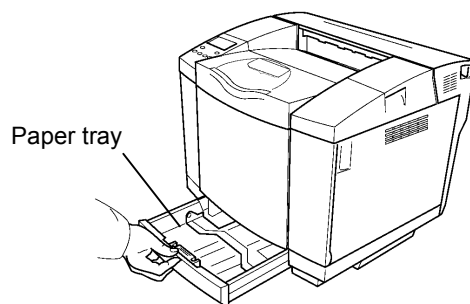

- (a) Draw out the paper tray from the printer.

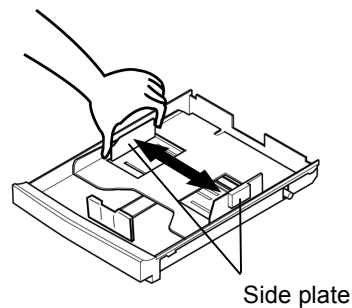

- (b) Hold the stopper on the pair of side plates, and adjust it to fit the width of the paper.

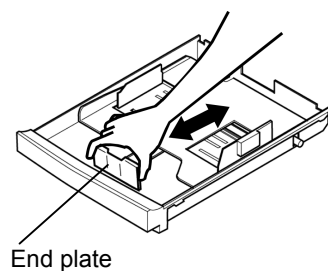

- (c) Hold the stopper on the end plate, and adjust it to fit the length of the paper.

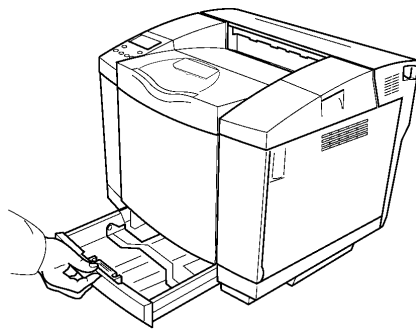
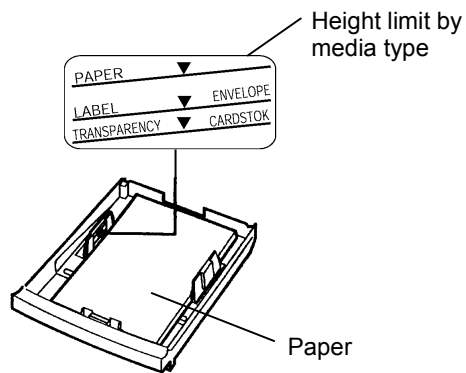

- (d) Supply paper (A4-size plain paper in this example) in the paper tray. Pay attention to the following:
- **Check that the four corners of the paper are set firmly in the paper tray.**
  - **Supply an appropriate amount of paper so that it does not exceed its height limit.**
- (e) Re-mount the paper tray into the printer.



## 8.2 Turning On the Printer

Turn on the printer according to the procedure below.

### Procedure for turning on the printer

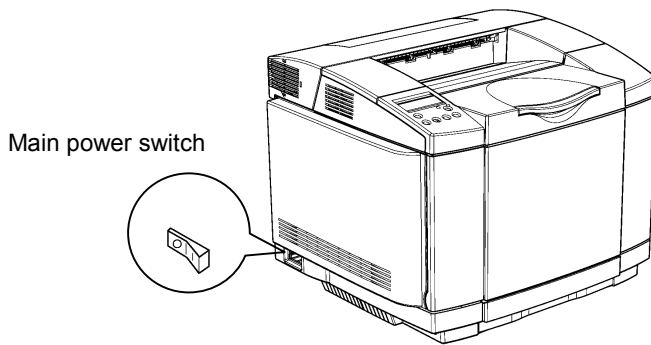

- (a) Press the main power switch of the printer to turn the printer power on.
  - **If the printer power does not turn on, see Operating Instructions attached to the CD-ROM.**

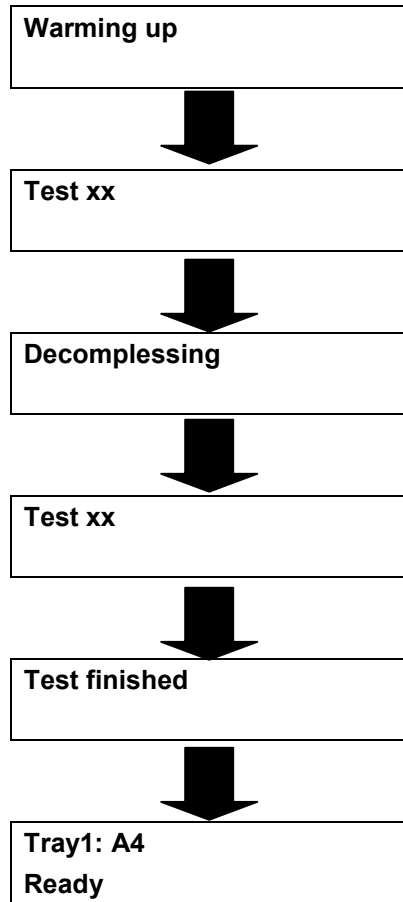

When you turn on the printer, ensure that the LCD in the control panel displays the information shown left.

If a printer error is detected:

If a printer error is detected, the ERROR lamp in the control panel turns on, and the display provides an error message.

For details of error messages and actions to be taken, see Operating Instructions attached to the CD-ROM.

## 8.3 Selecting the Panel Display Language

Select the panel display language according to the procedure below. For details, see Operating Instructions attached to the CD-ROM.

- You can select one of the following languages: English, German, French, Spanish, Italian, Japanese. The default setting is English.
- If you want to use the English panel display, it is not necessary for you to do the following procedures.

### Procedure for selecting the panel display language

- (a) Ensure that the control panel is displaying Ready.

Tray 1: A4  
Ready

- (b) Press ONLINE key.

Tray 1: A4  
Not Ready

- (c) Press MENU key, and ◀ or ▶ key to select Config Menu.

Tray 1: A4  
Config Menu

- (d) Press ENTER key, and ◀ or ▶ key to select Display submenu.

Tray 1: A4  
Display

- (e) Press ENTER key, and the current setting appears with an asterisk.

Tray 1: A4  
Display = ENGLISH \*

- (f) Press ◀ or ▶ key to select the target setting option.

Tray 1: A4  
Display = FRENCH

- (f) Press ENTER key to save the selected option as the new setting for the printer, suffixed with an asterisk.

Tray 1: A4  
Display = FRENCH \*

- (g) Press ONLINE key.

Tray 1: A4  
Ready

## 8.4 Performing Test Print

Perform test print according to the procedure below. For details about performing test print, see Operating Instructions attached to the CD-ROM.

### Procedure for performing test print

- (a) Ensure that the control panel is displaying Ready.

Tray 1: A4  
Ready

- (b) Press ONLINE key.

Tray 1: A4  
Not Ready

- (c) Press MENU key. (First)

Tray 1: A4  
Test Menu

- (d) Press MENU key. (Second)

Tray 1: A4  
TestPrint

- (e) Press MENU key. (Third)

Test print starts and the display blinks while printing.

When test print ends, the printer enters offline mode.

Tray 1: A4  
TestPrint

Tray 1: A4  
Not Ready

- (f) Press ONLINE key.

Tray 1: A4  
Ready

\_\_\_\_\_ If a printing error occurs: \_\_\_\_\_

If you find an error in the printed test pattern, see Operating Instructions attached to the CD-ROM.

## 8.5 Turning Off the Printer

Turn off the printer according to the procedure below.

### Procedure for turning off the printer

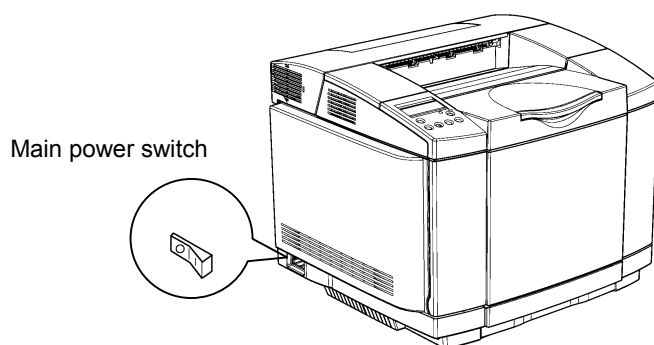

- (a) Check that the printer is not operating.  
After printing data or after closing the cover, wait for the operational noise to stop.
- (b) Turn off the main power switch of the printer.

## 9. Connecting the Printer to a PC

### Before connecting the printer to a PC

Before connecting the printer to the PC, check to make sure that the power to the printer main unit is switched off.

Connect the printer to a Windows® PC.

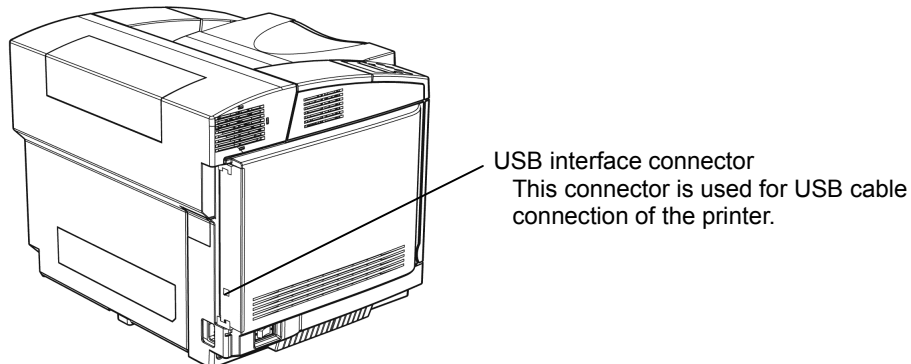

### 9.1 Setting the USB

(a) Connect a USB cable to the USB interface connector on the rear panel of the printer.

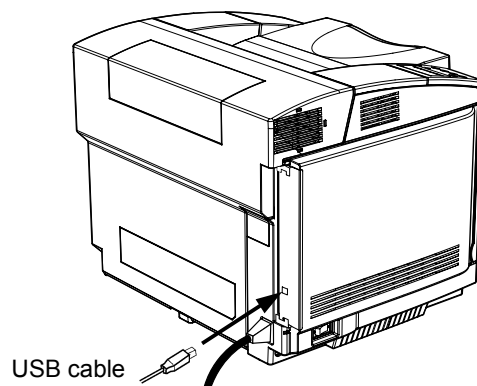

(b) Connect a USB cable to the Windows® PC.

Next, install the printer driver. The driver installation procedure varies depending on your PC's OS.

- Windows 98/Me: See page 2-23
- Windows 2000/XP/Server 2003: See page 2-25

# 10. Installing the Printer Driver

You must install the printer-driver into your personal computer before you print the document of the application software (i.e. MS-Word). Please install the printer-driver as following operations.

**Note: You need an authority of the administrator to install the printer-driver on Windows NT 4.0, Windows 2000, Windows XP and Windows Server 2003.**

## 10.1 System Environments

The printer driver can be used in the following system environment. The requirements of the following hardware components other than Operating System vary with an application used in conjunction with them.

	USB port (Only Ver.1.1)
Operating system *2	Windows 98 *1 Windows Me *1 Windows 2000 Windows XP Windows Server 2003
Microprocessor *3	Pentium® (133 MHz) or higher (Pentium® (200 MHz) or higher is recommended.)
Memory	64 MB or more (128 MB or more is recommended.)
Hard disk space *4	100 MB or more (300 MB or more is recommended.)
Display	Video Graphics Array (VGA: 640 dots by 480 dots) minimum. 256 colors or more (65536 colors or more is recommended.)

\*1 In Windows 98 and Windows Me which were upgraded from Windows 95, it may not operate normally.

\*2 I do not do limitation of hardware, in order that this printer driver may be dependent only on an operation system.

\*3 Windows NT, Windows 2000, Windows XP, and Windows Server 2003 printer driver can use only the X86 system CPU.

\*4 When printing by the lpr function of Windows NT, Windows 2000, Windows XP, or Windows Server 2003, it prints, after accumulating the data of a job in a spool. When you carry out extensive printing, please print, after an availability fully checks a certain thing.

## 10.2 Automatic Plug & Play Installation

You can install the printer driver on Windows machines easily using the Plug & Play automatic identification function.

**Note:** If the "Plug & Play" function is not started or the Device Driver Wizard dialog box is displayed, click the [Cancel] button and install the printer driver from add printer of printers folder

### 10.2.1 Windows 98/Me

There are some different operations according to the version of Operating System. Here, we show the operation in case of Windows 98 as follows.

#### Installation Steps

Before installation
Before starting to install the printer driver, check to make sure the following: <ul style="list-style-type: none"><li>● Power to the printer main unit is off.</li><li>● The PC is on.</li><li>● The printer and the PC are properly connected through a USB cable.</li></ul>

- 1.** Turn on the power to the printer.  
Windows 98/Me recognizes new hardware and starts a wizard to set up the printer driver.
- 2.** When the "Add New Hardware Wizard" window appears, click the [Next] button.
- 3.** Select "Search for the best driver for your device. (Recommended)." And click the [Next] button.

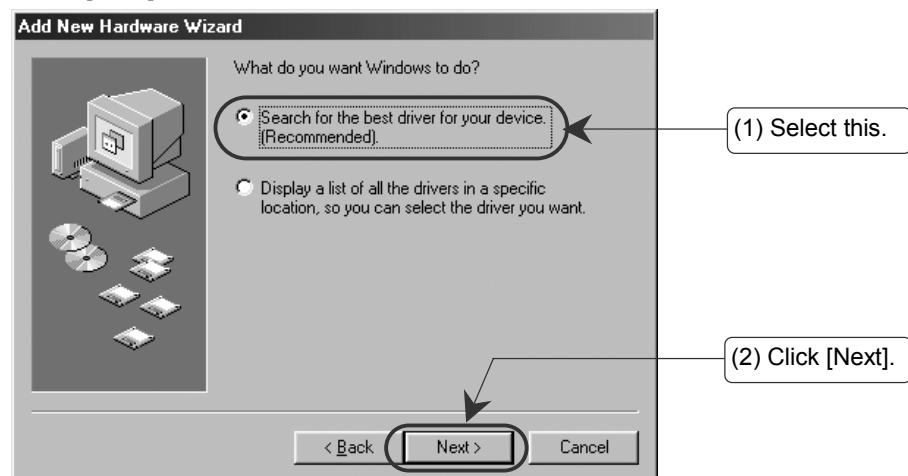

- 4.** Insert the printer driver CD-ROM into the CD-ROM drive (The explanation uses drive G as an example) and check the "Specify a location". Specify "G:\DRIVER\WIN98\EU\_ENG" and Click the [Next] button. You may also specify the source by clicking the [Browse] button.

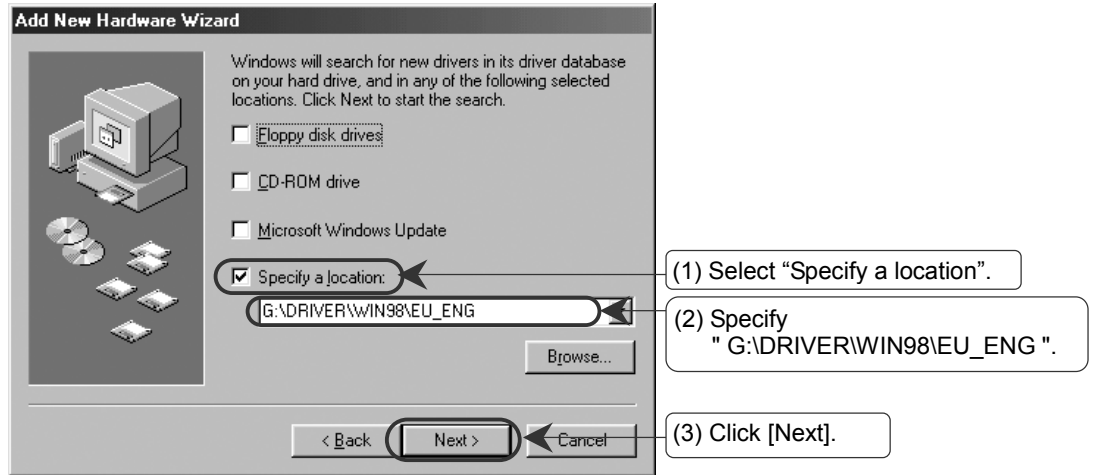

If your OS is Windows Me, enter "G:\DRIVER\WINME\EU\_ENG".

- 5.** If your PC does not have USB Printing Support installed:  
The location of USB Printing Support will be displayed. Then, click the [Next] button.

If you are using Windows Me or your PC has USB Printing Support installed already:

The location of the printer driver will be displayed. Then, click the [Next] button, and go on to Step 12.

- 6.** When the USB Printing Support installation is complete, a message will appear. Then, click the [Finish] button.
- 7.** A message that indicates the start of the printer driver search wizard will appear. Then, click the [Next] button.
- 8.** Select "Search for the best driver for your device. (Recommended)." And click the [Next] button.

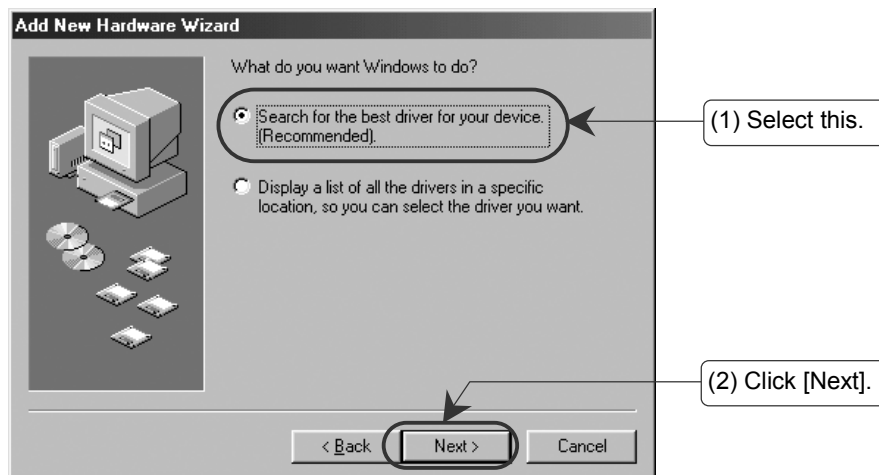



**9.** When the same window as that shown in Step 4 appears, click the [Next] button.

**10.** When the location of the printer driver is displayed, click the [Next] button.

**11.** Click the [Finish] button. The copy of the file begins.

**12.** Completing the "Add New Hardware Wizard". Click the [Finish] button.

The printer icon of the model name to be used in the printer window will be added.

## 10.2.2 Windows 2000/XP/Server 2003

There are some different operations according to the version of Operating System. Here, we show the operation in case of Windows 2000 as follows.

### Installation Steps

Before installation
Before starting to install the printer driver, check to make sure the following: <ul style="list-style-type: none"><li>● Power to the printer main unit is off.</li><li>● The PC is on.</li><li>● The printer and the PC are properly connected through a USB cable.</li></ul>

**1.** Turn on the power to the printer.

Windows 2000/XP/Server 2003 recognizes new hardware and starts a wizard to set up the printer driver.

**2.** When the "Welcome to the Found New Hardware Wizard" window appears, click the [Next] button.

**3.** Select "Search for a suitable driver for my device (recommended)." And click the [Next] button.

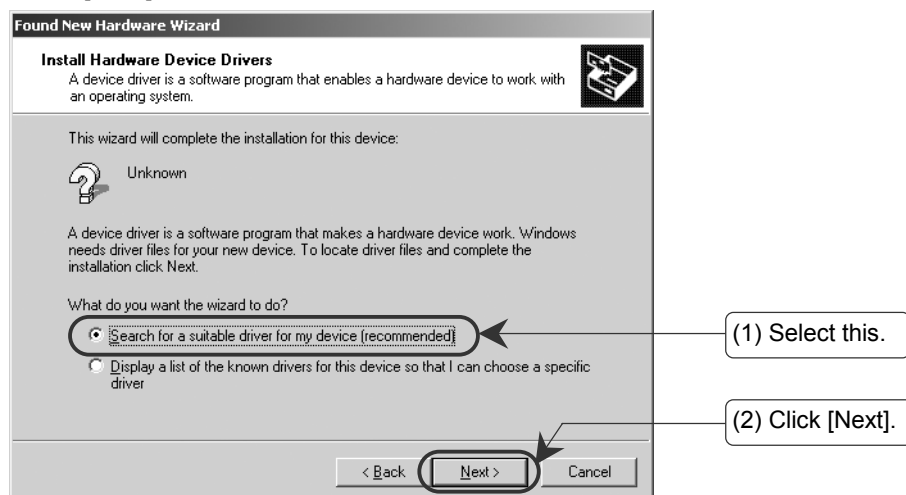

4. Search for the best driver for your device. Check the "Specify a location" and click the [Next] button.

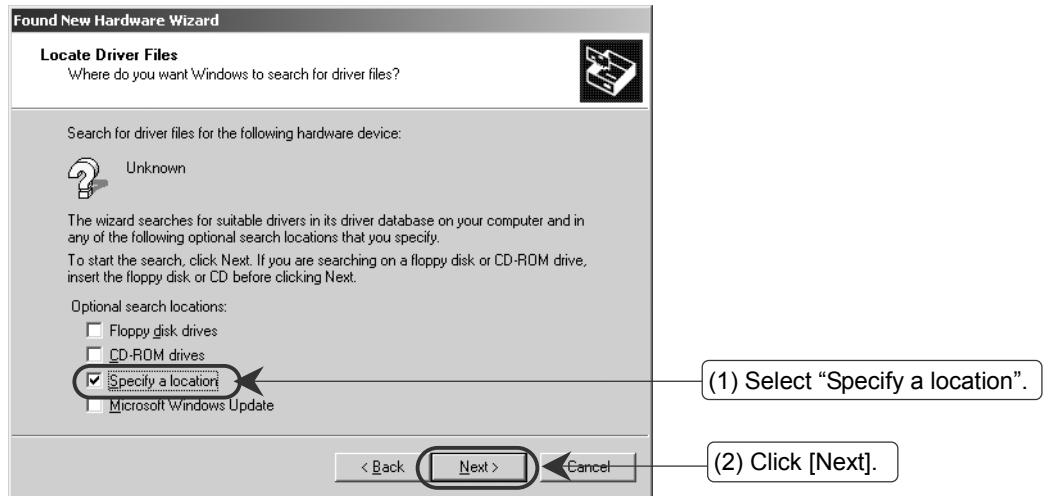

5. Insert the printer driver CD-ROM into the CD-ROM drive (The explanation uses drive G as an example). Specify "G:\DRIVERS\WIN2K\_XP\EU\_ENG" and click the [OK] button. You may also specify the source by clicking the [Browse] button.
6. When the "Driver Files Search Results" window appears, click the [Next] button.
7. If the "Digital Signature Not Found" window appears, click the [Yes] button. The copy of the file begins.
8. When the "Completing the Found New Hardware Wizard" window appears, click the [Finish] button.  
The printer icon of the model name to be used in the printer window will be added.



#### Declaration of Conformity

“The Product complies with the requirements of the EMC Directive 89/336/EEC and its amending directives and the Low Voltage Directive 73/23/EEC and its amending directives.”

In accordance with IEC 60417, this machine uses the following symbols for the main power switch:

**I** means **POWER ON**.

**O** means **POWER OFF**.

#### Notes:

Some illustrations in this manual might be slightly different from the machine.

Certain options might not be available in some countries. For details, please contact your local dealer.

#### Trademarks

Microsoft, Windows and Windows NT are registered trademarks of Microsoft Corporation in the United States and/or other countries.

IPS-PRINT Printer Language Emulation Copyright© 1999-2000 Oak Technology, Inc., All rights reserved.

Other product names used herein are for identification purposes only and might be trademarks of their respective companies. We disclaim any and all rights in those marks.

The proper names of the Windows operating systems are as follows:

**The product name of Windows® 95 is Microsoft® Windows® 95.**

**The product name of Windows® 98 is Microsoft® Windows® 98.**

**The product name of Windows® Me is Microsoft® Windows® Millennium Edition (Windows Me).**

**The product names of Windows® 2000 are as follows:**

Microsoft® Windows® 2000 Advanced Server

Microsoft® Windows® 2000 Server

Microsoft® Windows® 2000 Professional

**The product names of Windows® XP are as follows:**

Microsoft® Windows® XP Professional

Microsoft® Windows® XP Home Edition

**The product names of Windows Server™ 2003 are as follows:**

Microsoft® Windows Server™ 2003 Standard Edition

Microsoft® Windows Server™ 2003 Enterprise Edition

Microsoft® Windows Server™ 2003 Web Edition

**The product names of Windows NT® 4.0 are as follows:**

Microsoft® Windows NT® Server 4.0

Microsoft® Windows NT® Workstation 4.0



## RICOH COMPANY, LTD.

15-5, Minami Aoyama 1-chome,  
Minato-ku, Tokyo 107-8544, Japan  
Phone: +81-3-3479-3111

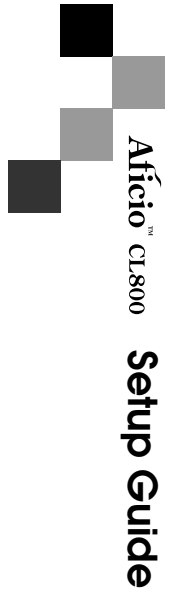

Aficio™ CL800  
Setup Guide

## Overseas Affiliates

### U.S.A.

RICOH CORPORATION  
5 Dedrick Place  
West Caldwell, New Jersey 07006  
Phone: +1-973-882-2000

### The Netherlands

RICOH EUROPE B.V.  
Groenelaan 3, 1186 AA, Amstelveen  
Phone: +31-(0)20-5474111

### United Kingdom

RICOH UK LTD.  
Ricoh House,  
1 Plane Tree Crescent, Feltham,  
Middlesex, TW13 7HG  
Phone: +44-(0)20-8261-4000

### Germany

RICOH DEUTSCHLAND GmbH  
Mergenthalerallee 38-40,  
65760 Eschborn  
Phone: +49-(0)6196-9060

### France

RICOH FRANCE S.A.  
383, Avenue du Général de Gaulle  
BP 307-92143 Clamart Cedex  
Phone: +33-(0)-821-01-74-26

### Spain

RICOH ESPAÑA S.A.  
Avda. Litoral Mar, 12-14,  
Blue Building, Marina Village,  
08005 Barcelona  
Phone: +34-(0)93-295-7600

### Italy

RICOH ITALIA SpA  
Via della Metallurgia 12,  
37139 Verona  
Phone: +39-045-8181500

### China

RICOH CHINA CO.,LTD.  
29/F., Lippo Plaza, No.222  
Huai Hai Zhong Road,  
Lu Wan District,  
Shanghai P.C.:200021  
Phone: +86-21-5396-6888

### Singapore

RICOH ASIA PACIFIC PTE.LTD.  
260 Orchard Road,  
#15-01/02 The Heeren,  
Singapore 238855  
Phone: +65-6830-5888

Model number: G132

Printed in The Netherlands

GB (GB) G132-8100